

Source Four® **PARNeI**®



User Manual

Production Dates: September 2004 - Present

Copyright © 2007 Electronic Theatre Controls, Inc.
All Rights reserved.
Product information and specifications subject to change.
Part Number: **7061M1250-06.01** Rev A
Released: July 2007

Table of Contents

Basic Assembly	1
Fixture information	2
Color frame holder	2
Replacing the HPL lamp	3
Focus knob positioning	4
Lens identification	4
Changing front lens	5
Cleaning glass lens	6
Cleaning the reflector	6

ETC[®], Emphasis[®], Expression[®], Insight[™], Imagine[™], Focus[™], Express[™], Unison[®], Obsession[®] II, ETCNet2[™], EDMX[™], Source Four[®], Revolution[®], Sensor[®], and WYSILink[™] are either registered trademarks or trademarks of Electronic Theatre Controls, Inc. in the United States and other countries.

All other trademarks, both marked and not marked, are the property of their respective owners.

Basic Assembly

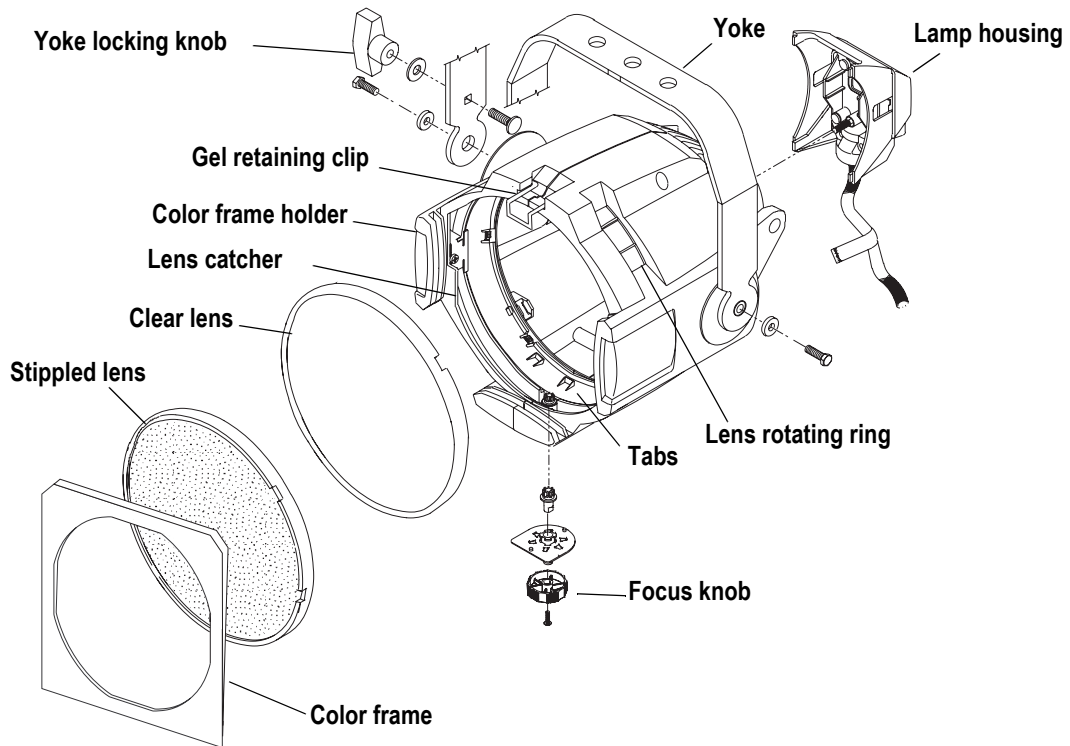

Figure 1



WARNING:

***Please note the following safety warnings before use:
Do not mount the fixture on or near combustible surfaces.
Do not operate the fixture without a lens installed.
Always hang the fixture with the color frame retaining clip in the locked position.***

Fixture information

HPL lamp table



CAUTION: Do not use lamps other than the HPL in Source Four fixtures. *Use of lamps other than HPL will void UL/cUL safety compliance and your warranty.*

Lamp code	Watts	Volts	Initial Lumen	Color temp.	Average rated life
HPL 780/77*	750	77	22,950	3,250°	300 hours
HPL 550/77*	550	77	16,170	3,250°	300 hours
HPL 550/77X*	550	77	12,160	3,050°	2000 hours
HPL 750/115	750	115	21,900	3,250°K	300 hours
HPL 750/115X	750	115	16,400	3,050°	1500 hours
HPL 575/115	575	115	16,520	3,250°K	300 hours
HPL 575/115X	575	115	12,360	3,050°K	2000 hours
HPL 375/115	375	115	10,540	3,250°K	300 hours
HPL 375/115X	375	115	8,000	3,050°K	1000 hours
HPL 750/120	750	120	21,900	3,250°K	300 hours
HPL 750/120X	750	130	16,400	3,050°K	1500 hours
HPL 575/120	575	120	16,520	3,250°K	300 hours
HPL 575/120X	575	120	12,360	3,050°K	2000 hours
HPL 750/230	750	230	19,750	3,200°K	300 hours
HPL 750/230X	750	230	15,600	3,050°K	1500 hours
HPL 575/230	575	230	14,900	3,200°K	400 hours
HPL 575/230X	575	230	11,780	3,050°K	1500 hours
HPL 375/230X	375	230	7,250	3,000°K	1000 hours
HPL 750/240	750	240	19,750	3,200°K	300 hours
HPL 750/240X	750	240	15,600	3,050°K	1500 hours
HPL 575/240	575	240	14,900	3,050°K	400 hours
HPL 575/240X	575	240	11,780	3,050°K	1500 hours
HPL 375/240X	375	240	7,250	3,000°K	1000 hours

* To be used with ETC Dimmer Doubler™

Color frame holder

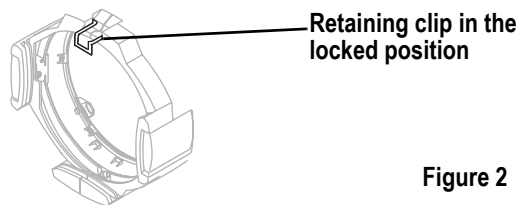

Figure 2

The color frame holder is equipped with a spring-loaded retaining clip that prevents color frames and accessories from falling out. See [Figure 2](#).



WARNING: *Make sure all color frame accessories are locked in position with the retaining clip before hanging the fixture.*

- Step 1: Release the retaining clip by pushing it sideways while gently pulling backwards.
- Step 2: Insert the color frame.

Step 3: Lock the retaining clip by pushing sideways while gently pushing forward.



Note: Use only color frames or accessories with 7.5 inch mounting flange.



Note: The performance of saturated colors may be less than desirable in any theatrical lighting fixture, especially when equipped with a 750w lamp. For best results, always use high-quality color media rated for high-temperature use.

ETC's optional Gel Extender, part # PSF1029, will provide maximum color media life. The use of any gel extender accessory may limit the coverage of any wide-angle lens or beam setting.

A variety of heat shield products is also available from many color media manufacturers. Follow the manufacturer's instructions for the use of these products.

Replacing the HPL lamp

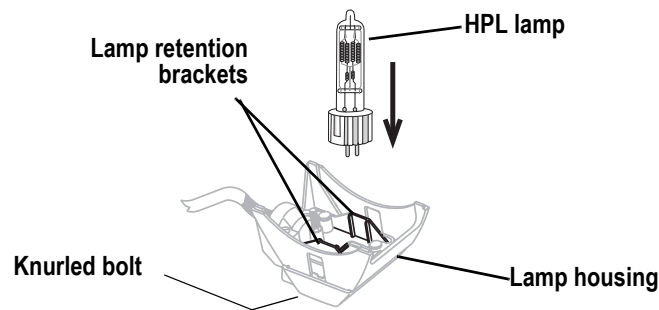

Figure 3

A lamp must be installed before you use the fixture.



Note: Verify that the HPL lamp you intend to install is suitable for your facility's voltage; 115-, 120-, 230-, and 240-volt HPL lamps are available. See [HPL lamp table, page 2](#). Operating HPL lamps above their rated voltage reduces lamp life and can cause premature lamp failure.



WARNING: Unplug the fixture and allow it to cool down before attempting to change the lamp.

Step 1: Disconnect power to the fixture before installing the lamp.

Step 2: Loosen the knurled bolt on the back of the lamp housing and pull the housing out.

Step 3: Holding by the base, remove the HPL lamp from its box.



CAUTION: Use caution when installing or replacing any lamp.

When installing/replacing lamp, be sure to point the lamp away from your face and away from others before inserting it firmly into the assembly.

This may prevent injuries if the lamp should break.

INCORRECT

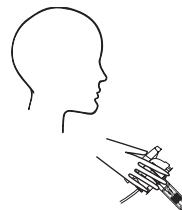

CORRECT



Note: To avoid premature lamp failure, do not touch the lamp glass. If you do, clean it carefully with isopropyl alcohol and a clean lint-free cloth. Allow to dry before operation.

Step 4: Align the flat sides of the lamp base with the retention brackets on either side of the socket as shown in [Figure 3](#).

Step 5: Push down on the lamp base until the lamp seats firmly. When properly installed, the top of the lamp's base will be even with the top edges of the retention brackets.



CAUTION: Improperly installed lamps cause premature lamp failure and socket problems.

Step 6: Press lamp retaining clip across lamp base to secure.

Step 7: Reinstall the lamp housing by aligning the bolt hole and tightening the knurled bolt.

Focus knob positioning

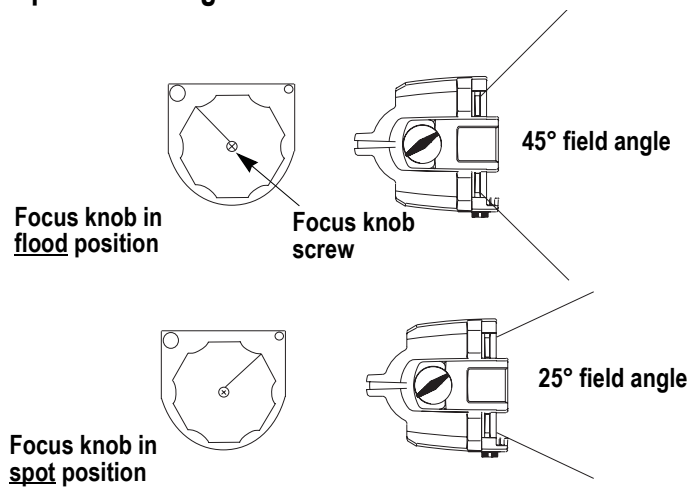

Figure 4

To adjust focus knob tension, loosen or tighten the focus knob screw. See [Figure 4](#).



CAUTION: Lens rotation knob does not rotate 360°. Do not attempt to exceed limit.

Lens identification

Lenses for the Source Four PARNel come in two versions. The wave/clear lens is in a fixed position in the rear of the fixture. The wave/stippled lens is in the rotating ring at the front of the fixture. The wave surfaces face each other.

Wave/Stippled Lens (WS)

Wave/Clear Lens (WC)

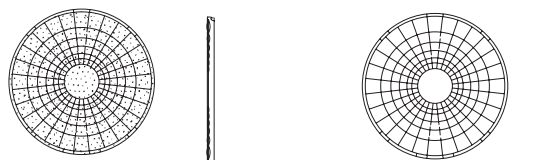

Figure 5

Changing front lens

Replace lens if it becomes cracked or badly scratched.



CAUTION: *Never operate the fixture without a lens in place.*



WARNING: *Unplug the fixture and allow it to cool down before attempting to change a lens.*

Removing a wave/stippled front lens

- Step 1: Place the fixture on a flat, stable work surface. **Do Not** remove or install lenses with fixture hanging.
- Step 2: Rotate the focus knob to the full spot position.
- Step 3: Tilt the front of the fixture down at least 45°. See [Figure 6](#).
- Step 4: Press the spring clip with your finger to release the lens.
- Step 5: Allow the lens to drop forward from under the clip.
- Step 6: When the lens drops, remove your finger, allowing the lens to slide forward until it rests on the lens catchers. See [Figure 7](#).
- Step 7: Carefully remove the lens.

Installing a wave/stippled front lens

- Step 1: Position the fixture with the front of the unit (lens side) facing you, and tilted slightly upward. See [Figure 8](#).
- Step 2: Rotate the focus knob to the full spot position.
- Step 3: Hold the lens by the edge and position it so the convex side faces the rear of the fixture.



Note: *Installing the front lens with the contoured side out will not impair the optics, but it will make removing the lens difficult.*

- Step 4: From the top of the fixture, slide the lens behind the lens catchers and position it behind the tabs on the bottom of the lens rotator ring.
- Step 5: Gently push the top of the lens inward until it snaps behind the spring clip.

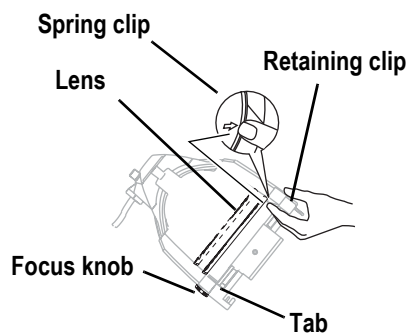

Figure 6

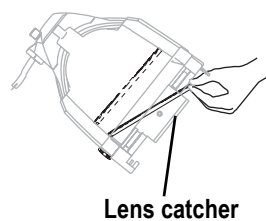

Figure 7

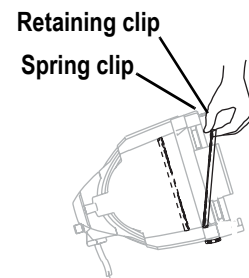

Figure 8

Positioning the wave/stippled front lens.

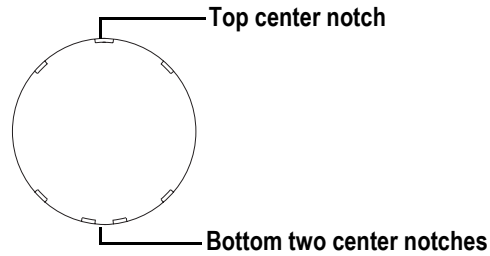

Figure 9

- Step 1: There are seven notches cut into the stippled side of the lens. Position the lens so the cluster of three notches is on top. The center notch of the cluster aligns with the spring clip on the lens retainer ring. See [Figure 9](#).
- Step 2: The bottom of the lens has a cluster of four notches. Place the two center notches behind the tabs at the bottom of the lens rotator ring.

Cleaning glass lens



WARNING: *Do not use ammonia-based or other harsh commercial cleaners. Clean lens only as directed.*

Commercially available glass cleaning agents should be avoided as they may contain ammonia, other harsh chemical detergents or abrasive agents. These cleaners may damage the glass surface and the Anti-Reflective coatings. Do not immerse or soak the glass in any cleaning solution.

Replace lenses if they contain visible damage (cracks or deep scratches) that may impair their effectiveness.

Remove dust with a blast of oil-free air or wipe with a clean, lint-free cloth. Isopropyl alcohol, distilled water or a 50%-50% mixture of each can be used to clean the glass surface.

Cleaning the reflector

The reflector is located behind the rear, fixed position wave/clear lens and requires disassembly of the fixture to access it. See the Source Four ParNel Assembly Guide for instructions on fixture disassembly/assembly.



Corporate Headquarters ■ 3031 Pleasant View Road, P.O. Box 620979, Middleton, Wisconsin 53562-0979 USA ■ Tel +608 831 4116 ■ Fax +608 836 1736
London, UK ■ Unit 26-28, Victoria Industrial Estate, Victoria Road, London W3 6UU, UK ■ Tel +44 (0)20 8896 1000 ■ Fax +44 (0)20 8896 2000
Rome, IT ■ Via Ennio Quirino Visconti, 11, 00193 Rome, Italy ■ Tel +39 (06) 32 111 683 ■ Fax +39 (06) 32 656 990
Holzkirchen, DE ■ Ohmstrasse 3, 83607 Holzkirchen, Germany ■ Tel +49 (80 24) 47 00-0 ■ Fax +49 (80 24) 47 00-3 00
Hong Kong ■ Rm 1801, 18/F, Tower 1 Phase 1, Enterprise Square, 9 Sheung Yuet Road, Kowloon Bay, Kowloon, Hong Kong ■ Tel +852 2799 1220 ■ Fax +852 2799 9325
Service: (Americas) service@etcconnect.com ■ (UK) service@etc europe.com ■ (DE) techserv-hoki@etcconnect.com ■ (Asia) service@etcasia.com
Web: www.etcconnect.com ■ Copyright © 2007 ETC. All Rights Reserved. ■ Product information and specifications subject to change.
7061M1250-06.01 ■ Rev A ■ Released 07/2007